

6-way Characterized Control Valve and 6-way Electronic Pressure Independent Valve Technical Documentation

Table of Contents

- Components Identification 3
- Overview 3
- Flow Characteristics 4
- Pressure Dependent and Pressure Independent Operation 4
- Flow Tolerances for ePIV models 5
- Features 6
- Nomenclature and Ordering Example for 6-way CCV. 7
- Nomenclature and Ordering Example for 6-way ePIV 8
- Product Range for 6-way CCV 9
- Product Range for 6-way ePIV 10
- Piping 11
- Mounting 12
- Installation Notes 13
- Wiring 14
- Replacement 14
- Control Mode Sequence of Operation for ePIV. 15
- NFC App 15
- ZTH US Tool 15
- BACnet PICS 16
- BACnet Object Description 18
- Modbus RTU 20
- Glossary 25

The 6-way valve is the only one of its kind designed for chilled beams, radiant ceiling panels, and 4-pipe fan coil units. It has the functionality of up to four 2-way control valves and two balancing valves saving material and installation time. The 6-way characterized control valve (CCV) with a non-spring return actuator is available in pressure dependent models and electronic pressure independent valve (ePIV) models. A single analog 2-10 VDC control signal throttles the control valve to operate two flow sequences (cooling/heating) for a single coil with one 90° rotary actuator. Electronic pressure independent models are furnished with actuator logic that utilizes feedback from the ultrasonic flow meter to maintain flow setpoint. Building management system (BMS) data integration is achieved with BACnet MS/TP, Modbus RTU, and Belimo MP-Bus communication protocol.

Pressure Dependent (6-way CCV)

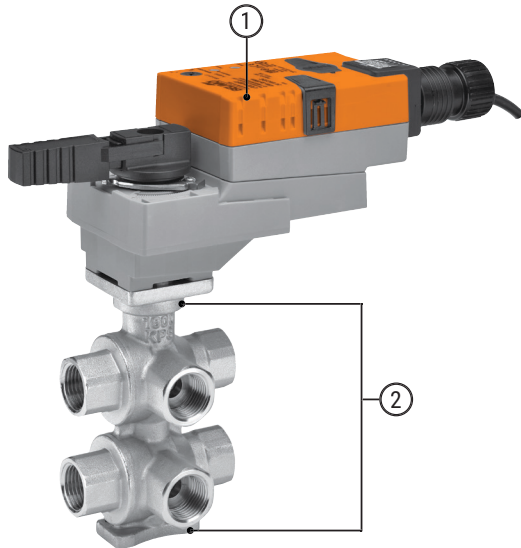

Electronic Pressure Independent (6-way ePIV)

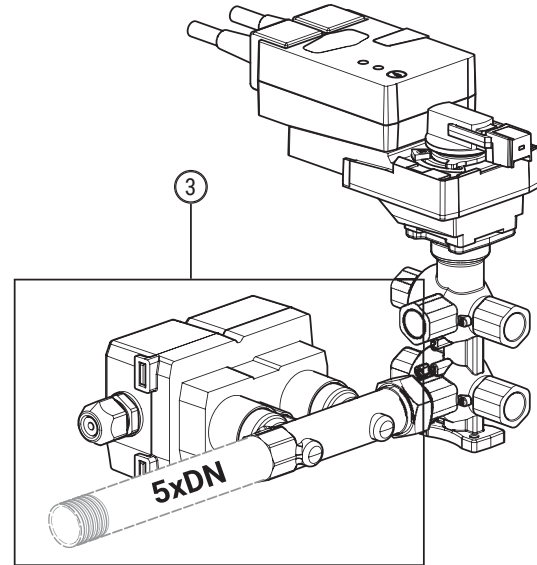

Actuator

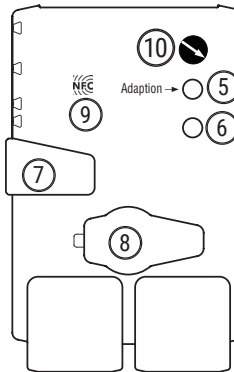
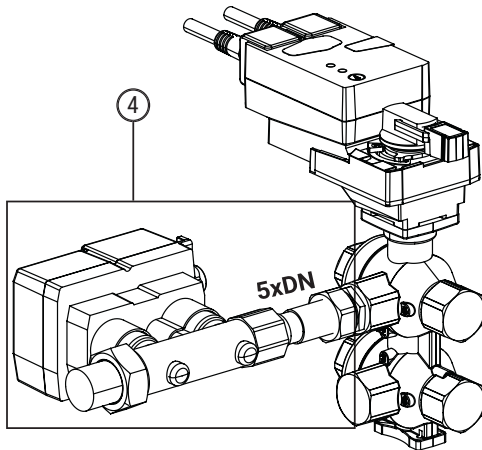

- ① Non-Spring Return Actuator (24 VAC/DC)
- ② 6-way Characterized Control Valve
- ③ Flow Sensor Installed in Return Pipe
- ④ Flow Sensor Mounted in Supply Pipe
- ⑤ Push Button and LED Display- Green
Off: No power supply or malfunction
On: In operation
Press Button: Triggers angle of rotation adaptation, followed by standard mode. Available only with 6-way ePIV

- ⑥ LED Display- Yellow
Off: Standard mode
On: Adaptation or synchronizing process active
Flickering: Modbus or BACnet communication active
Available only with 6-way ePIV
- ⑦ Gear Disengagement Button
Press Button: Gear disengages, motor stops, manual override possible
Release Button: Gear engages, synchronization starts, followed by standard mode
- ⑧ Service Plug: For connecting the ZTH US. Available only with 6-way ePIV
- ⑨ NFC Logo. Operated with Belimo Assistant App. Available only with 6-way ePIV
- ⑩ Direction of Rotation Switch. Available only with 6-way CCV

Flow Pattern

The flow direction must be observed. The position of the ball can be identified from the L-marking on the stem. Heating or cooling can be either sequence 1 or 2, but cooling is recommended for sequence 1. This valve is for closed loop systems ONLY.

Sequence 1

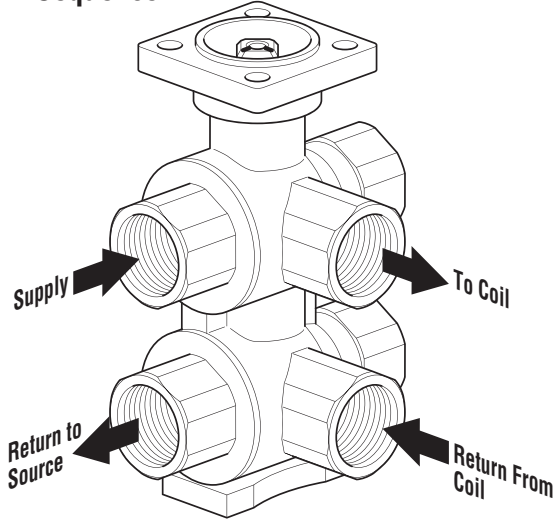

Sequence 2

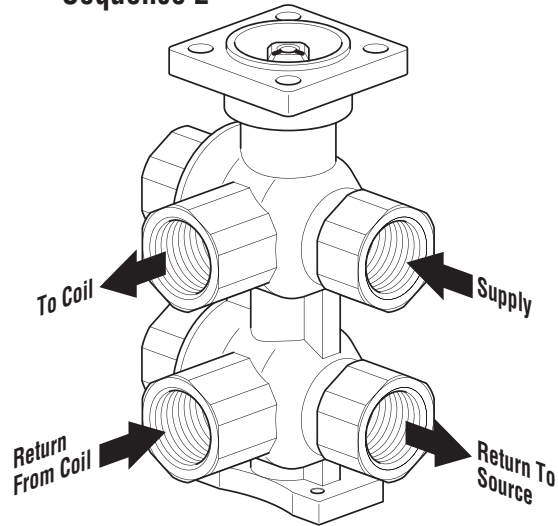

Pressure Dependent and Pressure Independent Valve Operation

The position of the ball is identified from the L-marking on the stem. The illustration shows the valve response vs. control signal for the 6-way CCV and the 6-way ePIV. The 6-way CCV will modulate to a valve position proportional to the control signal between closed and open. The 6-way ePIV will modulate to maintain the flow setpoint between zero and V'max.

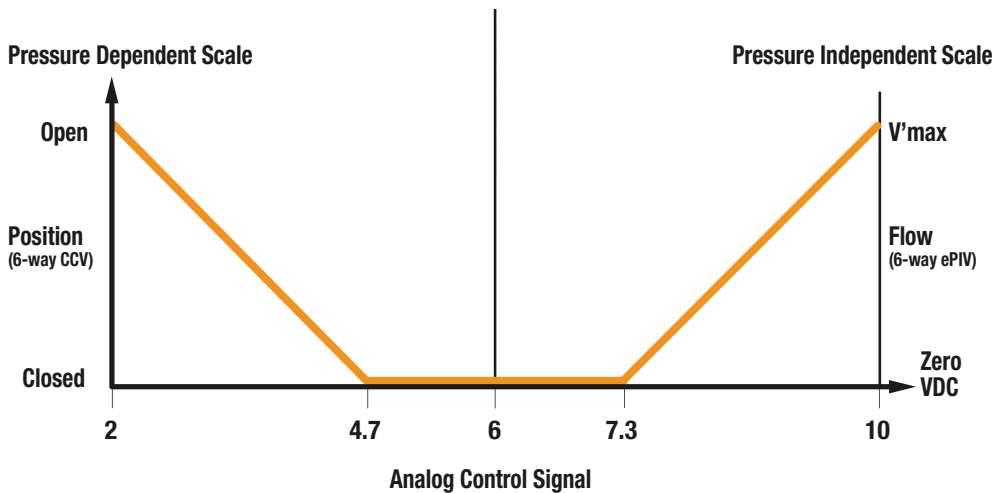
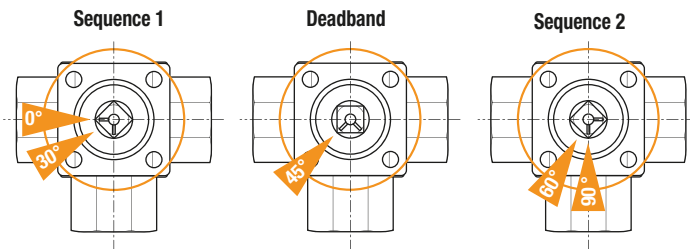

Flow Control for ePIV Models

Flow measurement tolerance is $\pm 2\%$ of the actual flow and flow control tolerance is $+6\%$ of the actual flow @ 68°F to 77°F [20°C to 25°C] and 0% glycol. 6-way ePIV has a linear flow curve for sequence 1 and sequence 2.

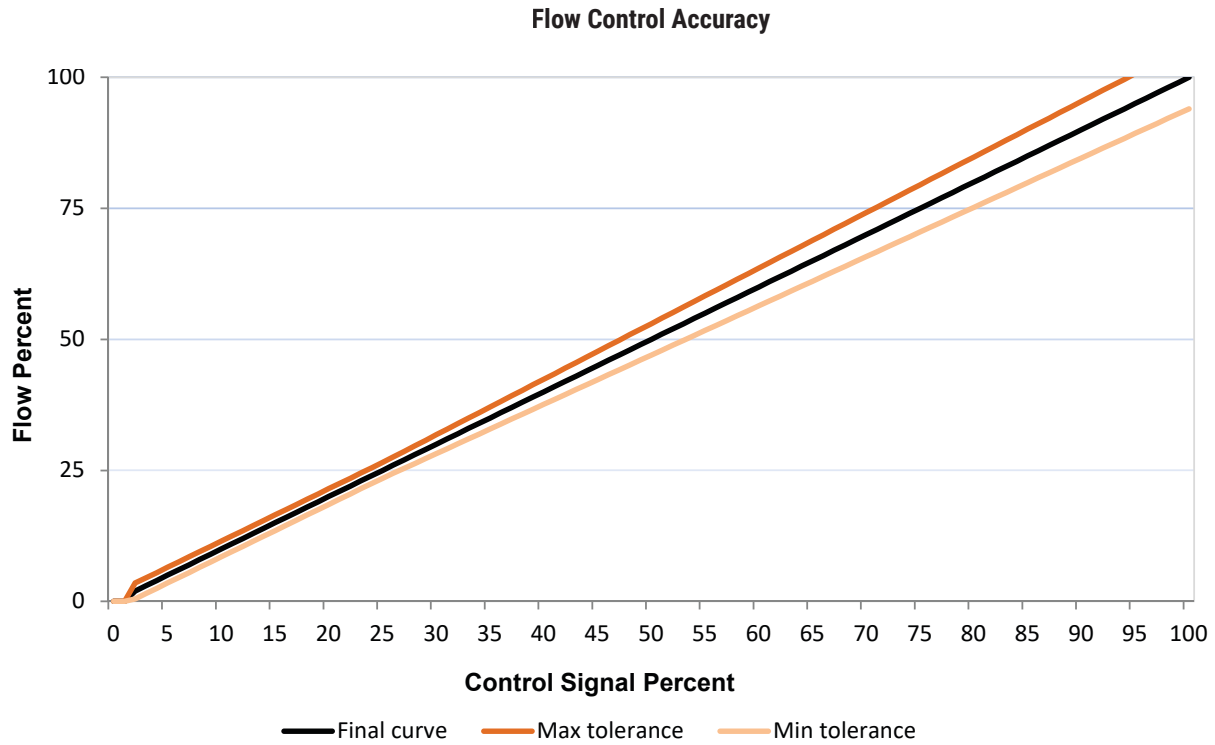

6-way CCV and 6-way ePIV Features



The Belimo 6-way pressure independent characterized control valve is the only one of its kind and is ideal for chilled beams and radiant ceilings. This compact valve has the functionality of up to four 2-way control valves saving space, material and installation time while providing true flow measurement.

- One valve performs change over and modulating control for single coil 4 pipe system providing less system maintenance.
- Support different flow requirements of both hot and chilled water with one valve (one valve multiple GPM's possible).
- True close-off to isolate both heating and cooling loops providing system efficiency.
- Less power consumption with using only one valve and actuator assembly.
- Reduced installation cost by using only one coil for heating and cooling.
- Near Field Communication (NFC) allows fast programming, commissioning and troubleshooting – even when the actuator is not powered it can be programmed
- Enhanced communication with BACnet MS/TP, and Modbus RTU provide superior application data access.
- True flow accuracy of $\pm 2\%$ with ultrasonic flow meter.

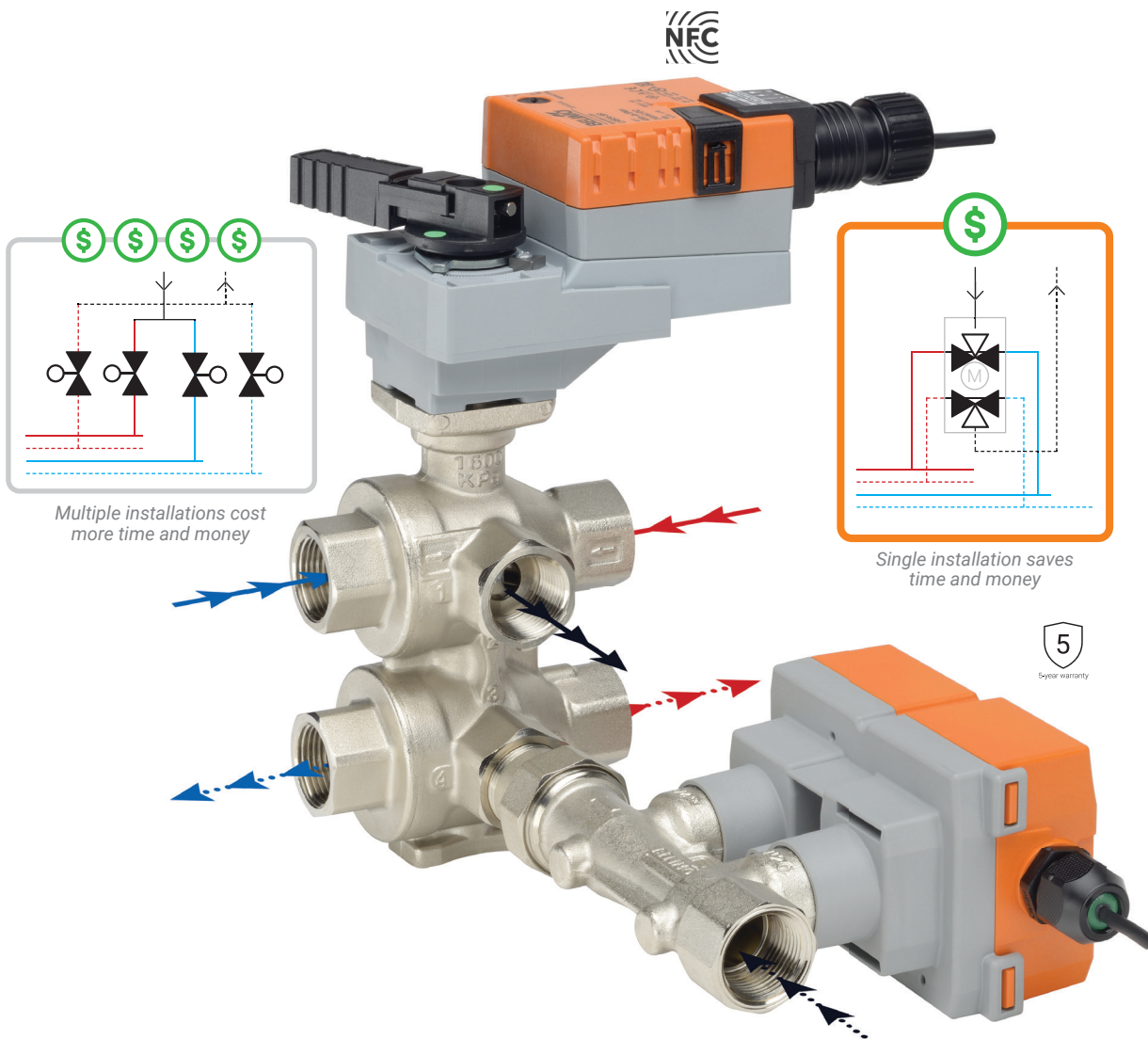

Tech.Doc - 08/21 - Subject to change. © Belimo Aircontrols (USA), Inc.

B3	15	-029	-	029	+LRB	24	-SR
Valve B3 = 3-way	Valve Size 15 = ½" 20 = ¾" 25 = 1"	Sequence 1 029 = 0.29 C _V 046 = 0.46 C _V 073 = 0.73 C _V 116 = 1.16 C _V 150 = 1.50 C _V 175 = 1.75 C _V 186 = 1.86 C _V 200 = 2.00 C _V 290 = 2.90 C _V 400 = 4.00 C _V 490 = 4.90 C _V 740 = 7.40 C _V	Two 3-way = 6-way	Sequence 2 029 = 0.29 C _V 046 = 0.46 C _V 073 = 0.73 C _V 116 = 1.16 C _V 150 = 1.50 C _V 175 = 1.75 C _V 186 = 1.86 C _V 200 = 2.00 C _V 290 = 2.90 C _V 400 = 4.00 C _V 470 = 4.70 C _V 700 = 7.00 C _V	Actuator Type LRB, LRX NRB, NRX	Power Supply 24 = AC/DC 24 V	Control -SR = 2...10 V -MFT = Multi-Function Technology Feedback = 2...10 V

Ordering Example

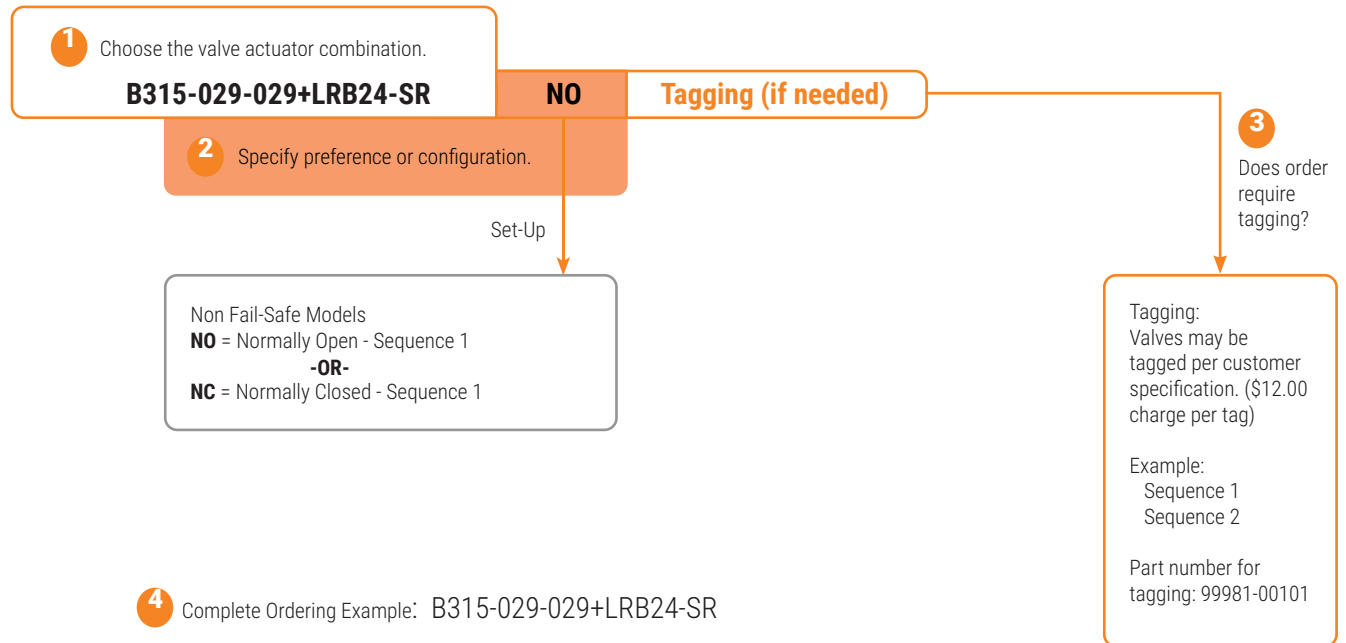

Tech.Doc - 08/21 - Subject to change. © Belimo Aircontrols (USA), Inc.

P3	050	B6	-K		+LRX	24	-LP-EP6	
Electronic Pressure Independent	Valve Size 050 = 1/2" 075 = 3/4"	6-Way Valve	Flow K = 5.5 GPM J = 10.3 GPM	Meter Installation Blank = Return S = Supply	Actuator Type LRX	Power Supply 24 = AC/DC 24 V	Modulating Control	Control Input = 2...10 V Feedback = 2...10 V

Ordering Example

1 Choose the valve actuator combination.

P3050B6-K+LRX24-LP-EP6

2 Specify maximum flow (Vmax)

Requested Flow S1
Vmax = 10...100% Vnom (nominal flow)

Requested Flow S2
Vmax = 10...100% Vnom (nominal flow)

S1 = Sequence 1
S2 = Sequence 2

3 Specify preference or configuration.

Set-Up
Non Fail-Safe Models
NO = Normally Open - Sequence 1

OR

NC = Normally Closed - Sequence 1

4 Does order require tagging?

Tagging:
Valves may be tagged per customer specification. (\$12.00 charge per tag)

Example:
Chilled/Heating Beam Room #1

Part number for tagging: 99981-00101

5 Complete Ordering Example: P3050B6-K+LRX24-LP-EP6

Requested Flow: S1: 4.0 GPM

S2: 1.0 GPM

Setup: NC

Tag: CB-01

NOTE: All models should be entered with the GPM designed - in case GPM is not provided this will come with V'nom set up.



5-year warranty



Linear Characteristic

Sequence 1 C _v	Sequence 2 C _v	Valve Nominal Size		Type	Suitable Actuators
		Inches	DN [mm]	6-way NPT	Non Fail-Safe
0.29	0.29	½	15	B315-029-029	LRB24-SR
0.29	0.46	½	15	B315-029-046	
0.29	0.73	½	15	B315-029-073	
0.29	1.16	½	15	B315-029-116	
0.29	1.5	½	15	B315-029-150	
0.46	0.29	½	15	B315-046-029	
0.46	0.46	½	15	B315-046-046	
0.46	0.73	½	15	B315-046-073	
0.46	1.16	½	15	B315-046-116	
0.46	1.5	½	15	B315-046-150	
0.73	0.29	½	15	B315-073-029	
0.73	0.46	½	15	B315-073-046	
0.73	0.73	½	15	B315-073-073	
0.73	1.16	½	15	B315-073-116	
0.73	1.5	½	15	B315-073-150	
1.16	0.29	½	15	B315-116-029	
1.16	0.46	½	15	B315-116-046	
1.16	0.73	½	15	B315-116-073	
1.16	1.16	½	15	B315-116-116	
1.16	1.5	½	15	B315-116-150	
1.5	0.29	½	15	B315-150-029	
1.5	0.46	½	15	B315-150-046	
1.5	0.73	½	15	B315-150-073	
1.5	1.16	½	15	B315-150-116	
1.5	1.5	½	15	B315-150-150	
1.75	2	½	15	B315-175-200	
2	1.75	½	15	B315-200-175	
2	2	½	15	B315-200-200	
0.73	0.73	¾	20	B320-073-073	
0.73	1.16	¾	20	B320-073-116	
0.73	1.86	¾	20	B320-073-186	
0.73	2.9	¾	20	B320-073-290	
1.16	0.73	¾	20	B320-116-073	
1.16	1.16	¾	20	B320-116-116	
1.16	1.86	¾	20	B320-116-186	
1.16	2.9	¾	20	B320-116-290	
1.86	0.73	¾	20	B320-186-073	
1.86	1.16	¾	20	B320-186-116	
1.86	1.86	¾	20	B320-186-186	
1.86	2.9	¾	20	B320-186-290	
2.9	0.73	¾	20	B320-290-073	
2.9	1.16	¾	20	B320-290-116	
2.9	1.86	¾	20	B320-290-186	
2.9	2.9	¾	20	B320-290-290	
2.9	4	¾	20	B320-290-400	
2.9	4.7	¾	20	B320-290-470	
4	2.9	¾	20	B320-400-290	
4	4	¾	20	B320-400-400	
4	4.7	¾	20	B320-400-470	
4.9	2.9	¾	20	B320-490-290	
4.9	4	¾	20	B320-490-400	
4.9	4.7	¾	20	B320-490-470	
7.4	7	1	25	B325-740-700	
					NRB24-SR
					NRX24-MFT

Tech.Doc - 08/21 - Subject to change. © Belimo Aircontrols (USA), Inc.

Mode of Operation

The control valve is operated by an electronic actuator that responds to a modulating 4...20 mA control signal. The actuator will then move the ball of the valve to the position dictated by the control signal thus changing the flow.

Product Features

Linear characteristic, complete close-off resulting in 0% leakage.

Actuator Specifications

Control type	2...10 V, multi-function technology (MFT)
Manual override	LR..
Electrical connection	3 ft. [1 m] cable with ½" conduit fitting

Valve Specifications

Fluid	chilled or hot water, 60% glycol
Flow characteristic	linear
Controllable flow range	
Sequence 1	(0...30° angle) Dead zone 30...60°
Sequence 2	(60...90° angle)
Sizes	½"
End fitting	NPT female
Materials	
Body	nickel plated brass
Ball	chrome plated brass
Stem	nickel plated brass
Seats	Teflon® PTFE
Seat O-rings	EPDM
Characterizing disc	chrome plated steel
Stem O-rings	EPDM
Fluid temperature range	43...180°F [6...82°C]
Body pressure rating	232 psi
Close-off pressure	50 psid
Maximum differential pressure (ΔP)	15 psid
Leakage	0%

Teflon® is a registered trademark of DuPont™.

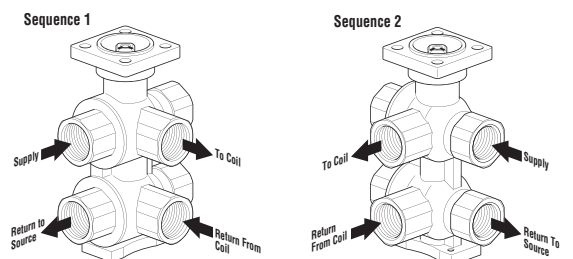

6-Way Electronic Pressure Independent Control Valve (ePIV) Product Range



Flow Vnom/GPM	Valve Nominal Size		Type	Suitable Actuators
	Inches	DN [mm]	ePI 6-way	Non Fail-Safe
5.5	½	15	P3050B6-K	LRX24-LP-EP6
5.5	½	15	P3050B6-KS	
10.3	¾	20	P3075B6-J	
10.3	¾	20	P3075B6-JS	

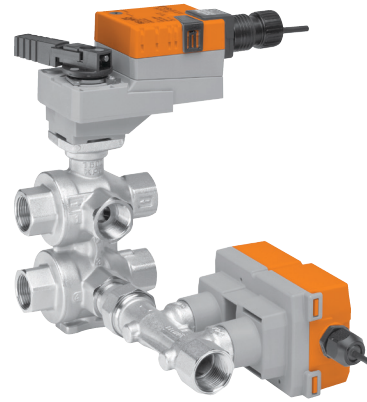

5-year warranty



Linear Characteristic

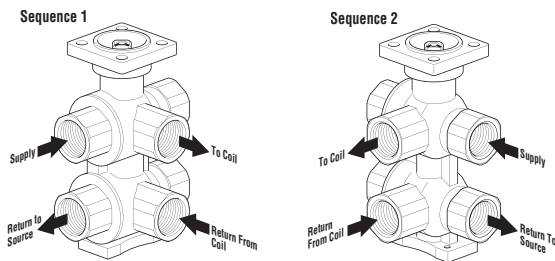

Mode of Operation

The control valve is operated by an electronic actuator that responds to a modulating 2...10 V control signal. The actuator will then move the ball of the valve to the position dictated by the control signal and change the flow.

Product Features

Linear characteristic, complete close-off.

Actuator Specifications

Control type	modulating
Manual override	LRX24-LP-EP6
Electrical connection	3 ft. [1 m] cable with ½" conduit fitting
Controllable flow range	90°
Communication	Analog, Belimo MP-Bus, BACnet MS/TP, Modbus RTU

Valve Specifications

Fluid	chilled or hot water, up to 60% glycol
Flow characteristic	linear
Controllable flow range	
Sequence 1	(0...30° angle) Dead zone 30...60°
Sequence 2	(60...90° angle)
Sizes	½", ¾"
End fitting	NPT
Materials	
Body	nickel plated brass
Ball	chrome plated brass
Stem	nickel plated brass
Seats	Teflon® PTFE
Seat O-rings	EPDM
Characterizing disc	chrome plated steel
Stem O-rings	EPDM
Fluid temperature range	43...180°F [6...82°C]
Body pressure rating	232 psi
Close-off pressure	50 psid
Minimum differential pressure at V _{nom}	7 psi
Leakage	0%
Rangeability	100:1
Flow control tolerance	±6%
Flow measurement tolerance	±2%
All flow tolerances @ 68...77°F [20...25°C] and 0% glycol.	

Tech.Doc - 08/21 - Subject to change. © Belimo Aircontrols (USA), Inc.

Four Pipe Common Load Systems

As with all combined heating/cooling elements in 4-pipe systems, mass displacement can occur.

Mass Displacement

With each switch (from cooling to heating operation or from heating to cooling operation) water is displaced from one circuit to the other. Due to the different medium temperatures, the density of this water differs. Due to the constant volume in the heating/cooling element, the quantity of water displaced has a different mass. When switching from cooling to heating, more mass is shifted than when switching from heating to cooling. This mass displacement can lead to the cooling circuit being emptied.

It is important to compensate for this normal behavior.

Media

Due to the mass displacement that occurs, the medium in both circuits needs to have the same properties (glycol concentration).

System Pressure

The system pressures in the heating and cooling circuit must have the same value.

Built-in Pressure Relief

A loop pressure relief is designed into port number two (2). This allows the increased pressure to dissipate to the supply loop on port number one (1). This is intended to release any pressure build up in the loop (coil) when the valve is in the closed position and is isolated from the system expansion vessel. The change in pressure occurs due to a change in the media temperature in the coil while isolated from the pressure vessel. The pressure relief does not affect the efficiency of the system because cross-flow cannot occur between the heating and cooling loops.

Max $\Delta P^* = Dp_{source} - Dp_{coil}$

Dp_{source} = differential pressure between supply and return of the source (Ports 1 & 4 or 5 & 6)

Dp_{coil} = differential pressure between supply and return of the Coil (Ports 2 & 3)

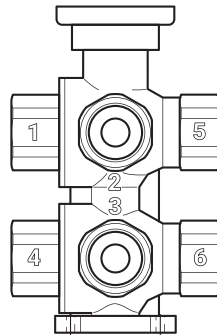

Recommended Installation

1. One expansion vessel*

- One expansion vessel for both circuits. Connection point on the suction side of the pumps.
- Pumps at the same height.
- Connection line between heating circuit return and cooling circuit return.
- The same static pressure on the suction side of the pumps.

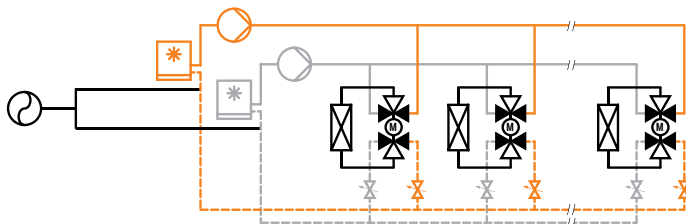

2. Two expansion vessels in a hydraulic coupling system

- The same static pressure on the suction side of the pumps.
- Pumps at the same height.
- The 2-way valve remains closed during operation.
- The 2-way valve will open if the pressures $p_{Heating}$ and $p_{Cooling}$ exhibit a certain difference due to the mass displacement.
- The system pressures are balanced.
- The 2-way valve is closed again after the compensation.

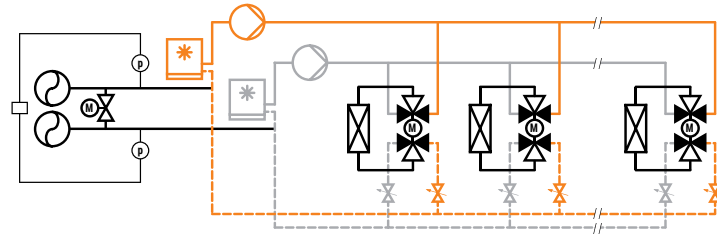

3. One expansion vessel with dedicated resource

- Secondary circuit isolated from the primary via dedicated source (IE: Heat Exchangers, Heat Pumps, Boilers, Chillers.)
- One expansion vessel for both circuits.
- Pumps at the same height.
- Connection line between heating circuit return and cooling circuit return.
- The same static pressure on the suction side of the pumps.

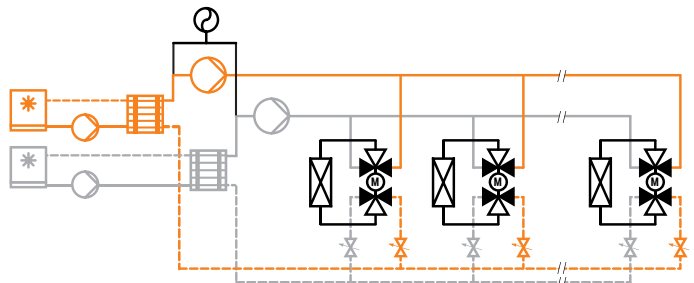

Non-Recommended Installation

4. Two expansion vessels

- The effect of mass displacement must be compensated for by refilling and emptying the circuit.

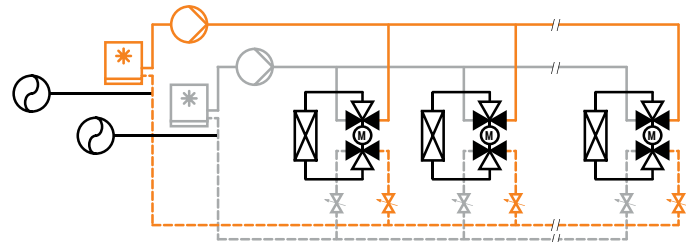

*Per ASHRAE mechanical piping handbook, 4-pipe common load system should share a common expansion tank.

Mounting

The control valve can be mounted either vertically or horizontally.
Do not install the ball valve with the stem pointing downwards.

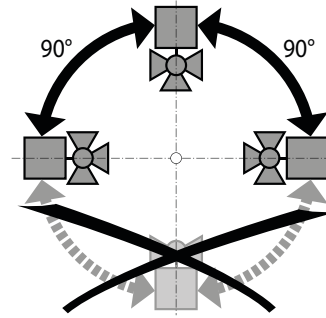

Flow Reduction Chart

MAXIMUM FLOW BASED ON MINIMUM DIFFERENTIAL PRESSURE FOR 6-WAY EPIV

Size		7 psid	6 psid	5 psid	4 psid	3 psid	2 psid	1 psid
Inches	DN [mm]							
½	15	5.5 GPM	5.0 GPM	4.6 GPM	4.1 GPM	3.5	2.9 GPM	2.1 GPM
¾	20	10.3 GPM	10.2 GPM	9.3 GPM	8.3 GPM	7.2 GPM	5.9 GPM	4.2 GPM

The differential pressure across the valve is:

$$Dp_{\text{valve}} = Dp_{\text{source}} - Dp_{\text{coil}}$$

Where:

Dp_{valve} = differential pressure across the valve

Dp_{source} = differential pressure between supply and return of the source

Dp_{coil} = differential pressure between supply and return of the coil

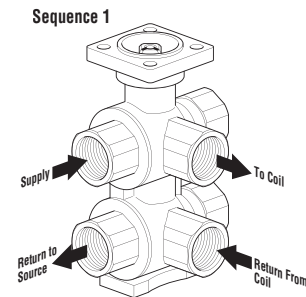

Installation

Inspect shipping package, valve, linkage, and actuator for physical damage. If shipping damage has occurred notify appropriate carrier. Do not install.

1. Install valve with the proper ports as inlets and outlets. See drawings on page 1. Flow direction arrows must be correct.
2. Blow out all piping and thoroughly clean before valve installation.
3. Clean male pipe threads with wire brush and rag. If threads have been damaged or exposed to weather, running a tap or die over the threads may straighten them. Clean pipes, threads, and valve threads before installation; check for any foreign material that can become lodged in trim components. Strainers should be cleaned after initial startup.
4. Pipe sealing compound should be applied sparingly after cleaning and may not be applied to the two lead threads of a screwed pipe, which are innermost inside the valve. Sealing compound is to be placed on male threads only. The purpose is to lubricate the pipes when tightening.
5. Valve must be installed with the stem towards the vertical, not below horizontal.
6. Start the connection by turning the valve or pipe by hand as far as possible. Be certain the threads mate by the "feel" of the connection.
7. Use wrenches to tighten the valve to the pipe. Do not over tighten or strip the threads. Two wrenches are necessary to avoid damaging the valve.
8. Valves must be installed in closed loop systems only.

Do not force. Do not use the actuator to turn the pipe or the stem. Do not use any toothed tool such as pliers, which may damage the stem.

Warning!

- Valve should not be used for combustible gas applications. Gas leaks and explosions may result. Do not install in systems, which exceed the ratings of the valve.
- Avoid installations where valve may be exposed to excessive moisture, corrosive fumes, vibration, high ambient temperatures, elements, or high traffic areas with potential for mechanical damage.
- Valve assembly location must be within ambient ratings of actuator. If temperature is below -22°F a heater is required.
- The valve assembly will require heat shielding, thermal isolation, or cooling if combined effect of medium and ambient temperatures – conduction, convection, and radiation – is above 180°F for prolonged time periods at the actuator.
- Following standard procedure, a strainer should be installed before the coil and valve or in another appropriate place in the system.
- Visual access must be provided. Assembly must be accessible for routine schedule service. Contractor should provide unions for removal from line and isolation valves.
- Avoid excessive stresses. Mechanical support must be provided where reducers have been used and the piping system may have less structural integrity than full pipe sizes.
- Sufficient upstream and downstream piping runs must be provided to ensure proper valve capacity and flow response. Five diameters in each direction are recommended.
- Life span of valve stems and O-rings is dependent on maintaining non-damaging conditions. Poor water treatment or filtration, corrosion, scale, other particulate can result in damage to trim components. A water treatment specialist should be consulted.
- Normal thread engagement between male pipe thread and valve body should be observed. Pipe run that is in too far will damage the valve.

Storage: The valves should be stored in the open or closed position. The valves must always be either completely open or completely closed to avoid deformation of the PTFE seat on one side. The valves must be protected against dust and dirt.

Wiring

✂ INSTALLATION NOTES

- Provide overload protection and disconnect as required.
- Actuators may be connected in parallel. Power consumption and input impedance must be observed.
- Actuators are provided with color coded wires. Wire numbers are provided for reference.
- NFC
- Meets cULus requirements without the need of an electrical ground connection.
- WARNING! LIVE ELECTRICAL COMPONENTS!**
During installation, testing, servicing and troubleshooting of this product, it may be necessary to work with live electrical components. Have a qualified licensed electrician or other individual who has been properly trained in handling live electrical components perform these tasks. Failure to follow all electrical safety precautions when exposed to live electrical components could result in death or serious injury.
- Actuators may also be powered by DC 24 V.
- Only connect common to negative (-) leg of control circuits.
- A 500 Ω resistor (ZG-R01) converts the 4...20 mA control signal to 2...10 V.
- Control signal may be pulsed from either the Hot (Source) or Common (Sink) 24 V line.
- For triac sink the Common connection from the actuator must be connected to the Hot connection of the controller. Position feedback cannot be used with a triac sink controller; the actuator internal common reference is not compatible.
- IN4004 or IN4007 diode. (IN4007 supplied, Belimo part number 40155).
- Actuators with plenum cable do not have numbers; use color codes instead.

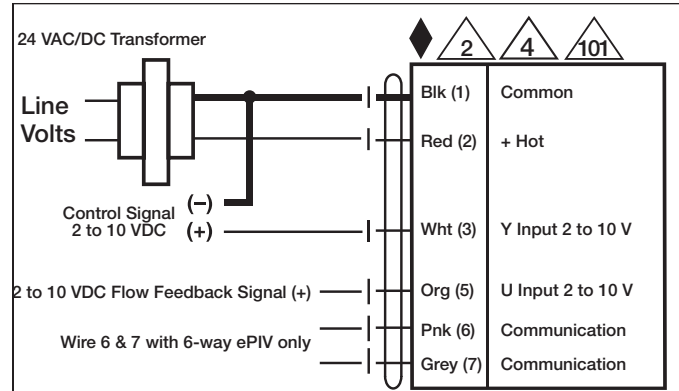

2 to 10 VDC Control

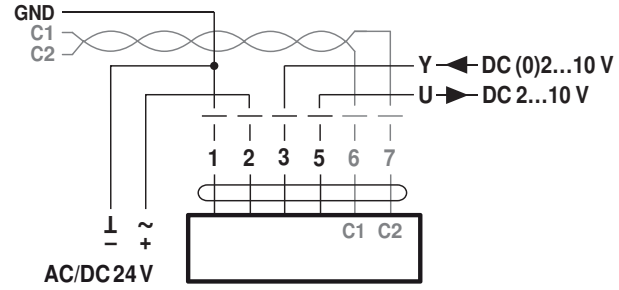

Communication/Modbus RTU Wiring/BACnet MS/TP Wiring

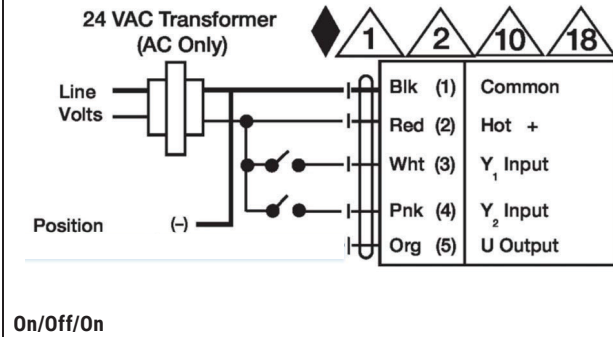

6-way ePIV Replacement

The actuator and flow sensor must be replaced as a unit. To replace, separate the flow unit from the valve assembly, unthread the coupler/union that connects the flow unit to the control valve assembly. Unscrew the single actuator mounting screw and remove the actuator.

IMPORTANT: The flow sensor is directly embedded in the flow unit. Before removing the flow sensor, the system must be relieved of pressure, drained and or closed directly upstream and downstream of the valve to circumvent any system leakage. The valve must not be lifted from the flow sensor or actuator. Disassembly and or lifting by the actuator or flow sensor will damage the assembly and void warranty.

Control Mode Sequence

Flow Control

The device works as an ePIV (Electronic Pressure Independent Valve). The valve reacts to any change in pressure, the actuator logic with True Flow feedback modulates the valve to maintain the heating and cooling flow setpoint. Flow setpoint is with BACnet or Modbus communication or with a single 2-10 VDC or 0.5-10 VDC analog control signal. $V'max$ (design flow setting) is adjustable from 5% to 100% of $V'nom$ (maximum flow capacity of each sequence. $V'max1$ is the maximum design flow setting for sequence 1, and $V'max2$ is the maximum design flow setting for sequence 2.

Position Control

The device works as a pressure dependent 6-way CCV with True Flow status feedback. The control signal modulates the valve position.

Opening and Closing Logic for Flow Control

The valve remains closed until the control signal (flow setpoint) is greater than or equal to 1% of $V'nom$, then it will open and modulate to maintain the flow setpoint within the control tolerance.

An open valve will modulate within the control tolerance to maintain the control signal (flow setpoint) when it is greater than or equal to 1% of $V'nom$. The flow rate is maintained at 1% of $V'nom$ when the flow setpoint is between 0.5% to 1% of $V'nom$. The valve will close when the flow setpoint is below 0.5% of $V'nom$.

Adaptation logic

The first time the supply voltage is switched on, i.e. at the time of commissioning, the actuator carries out an adaptation, which is when the operating range and position feedback adjust themselves to the mechanical setting range. After this process the actuator moves into the required position in order to ensure the flow rate defined by the control signal.

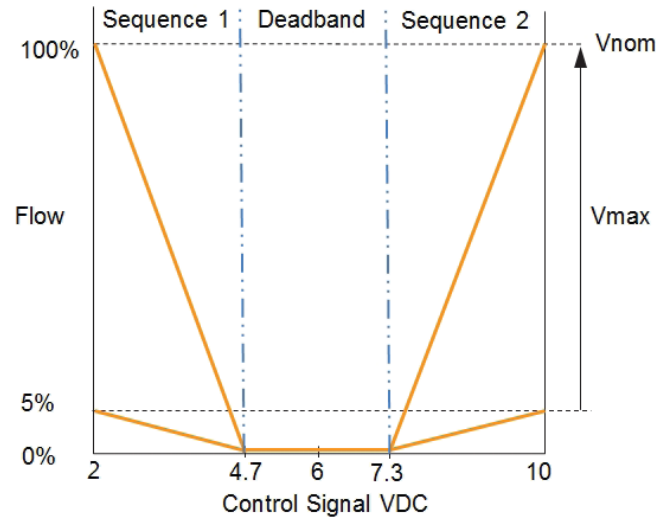

ePIV Sequence Response vs. Control Signal Input

NFC App

Near Field Communication (NFC) allows fast programming, commissioning and troubleshooting; even when the actuator is not powered, it can be programmed. Simply download and install the Belimo Assistant app from the Apple Store (Belimo gateway part# ZIP-BT-NFC is required) or on Google Play. Align the smartphone to the actuator, access data, and write new program values to the actuator.

The NFC App includes three data screens:

Dashboard: Valve location text, actuator series details, and basic system information such as the actuator sequence position, running time, status of power supply, and flow.

Configuration: Settings for $V'max$, control signal input, control mode (position or flow), BACnet or Modbus settings, and override options for sequence 1&2.

Diagnosis: Health status for the valve actuator and flow meter.

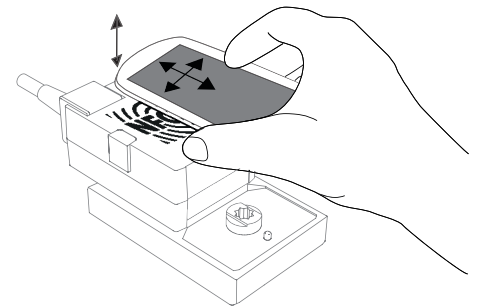

ZTH US

Connect the ZTH US hand-held tool to the actuator service plug to view and set parameters; the actuator must be powered. The data options are similar to those found in the NFC app.

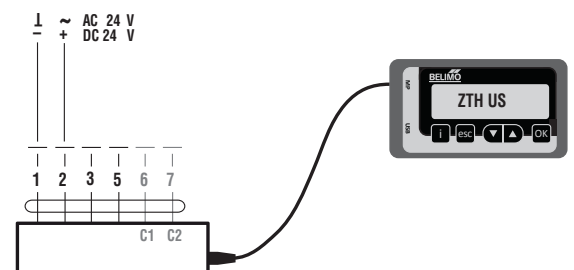

Protocol Implementation Conformance Statement - PICS

General information	Date:	12 December 2016
	Vendor Name:	BELIMO Automation AG
	Vendor ID:	423
	Product Name:	6way EPIV
	Product Model Number:	P3...-LP-EP6, e.g. P3050B6-K+LRX24-LP-EP6
	Applications Software Version:	01.02.0410
	Firmware Revision:	07.01.0000
	BACnet Protocol Revision:	1.12
	Product Description:	Electronic pressure-independent 6 way characterized control valve.
	BACnet Standard Device Profile:	BACnet Application Specific Controller (B-ASC)
	BACnet Interoperability Building Blocks supported:	
		Data Sharing - ReadProperty-B (DS-RP-B)
		Data Sharing - ReadPropertyMultiple-B (DS-RPM-B)
		Data Sharing - WriteProperty-B (DS-WP-B)
	Data Sharing - WritePropertyMultiple-B (DS-WPM-B)	
	Device Management - DynamicDeviceBinding-B (DM-DDB-B)	
	Device Management - DynamicObjectBinding-B (DM-DOB-B)	
	Device Management - DeviceCommunicationControl-B (DM-DCC-B)	
Segmentation Capability:	No	
Data Link Layer Options:	MS/TP master, baud rates: 9'600, 19'200, 38'400, 76'800, 115'200	
Device Address Binding:	No static device binding supported	
Networking Options:	None	
Character Sets Supported:	ANSI X3.4	

PICS

Object processing

Object type	Optional properties	Writeable properties
Analog Input [AI]	Description	
Analog Output [AO]	Description	Present Value Relinquish Default
Analog Value [AV]	Description	Present Value
Binary Value [BV]	Description Active Text Inactive Text	
Device	Description Location Max Master Max Info Frames Profile Name	Object Identifier Object Name Location Description APDU Timeout Number Of APDU Retries Max Master Max Info Frames
Multi-state Input [MI]	Description State Text	
Multi-state Value [MV]	Description State Text	Present Value
Multi-state Output [MO]	Description State Text	Present Value Relinquish Default

- The properties Object Name, Location and Description of the Device Object support up to 255 characters (all other character strings are read-only).
- The device does not support the CreateObject and DeleteObject service.

Service processing

- The device supports DeviceCommunicationControl service. No password is required.

BACnet object description

Object Name	Object Type / Instance	Description Comment	Values	Default	Access
Device Name	Device[x]				
SpRel	AO [1]	Setpoint Relative in % ¹⁾ <i>The set point is related either to the position or the flow (of Vmax)</i>	0 ... 100	50	C
Override	MO [1]	Override Control	None Seq1 Open Seq2 Open Close Seq1 Vmax Seq2 Vmax	None	C
RelPos	AI [1]	Relative Position in %	0 ... 100	-	R
AbsPos	AI [2]	Absolute Position in °	0 ... 90	-	R
SpAnalog_V	AI [5]	Setpoint Analog in V	0 ... 10	-	R
RelFlow	AI [10]	Relative Flow in % <i>Related to Vmax</i>	0 ... 100	-	R
AbsFlow_lh	AI [15]	Absolute Flow in l/h	0 ... Vnom	-	R
AbsFlow_gpm	AI [18]	Absolute Flow in gpm	0 ... Vnom	-	R
AbsFlow_UnitSel	AI [19]	Absolute Flow in selected unit → MV [121]	0 ... Vnom	-	R
SpAbsFlow_UnitSel	AI [109]	Setpoint Absolute Flow in selected unit → MV [121]	0 ... Vnom	-	R
ActSequence	MI [1]	Active Sequence	Sequence 1 Sequence 2 Dead Band	-	R
SummaryStatus	BI [101]	Summary Status <i>Summarizes all status from MI 103 - 106</i>	OK not OK	-	R
StatusSens	MI [103]	Status Sensor <i>Indicates informations within the flow sensor</i>	OK Flow sensor not OK	-	R
StatusFlow	MI [104]	Status Flow <i>Setpoint cannot be reached within 3min during flow control Flow is measured but position of valve is closed (Dead band)</i>	OK Flow not reached Flow in closed position	-	R
StatusMedia	MI [105]	Status Media <i>Airbubbles in the hydronic system</i>	OK Airbubbles	-	R
StatusAct	MI [106]	Status Actuator <i>Mechanical overload e.g. blocked valve Gear disengaged button is pressed</i>	OK Actuator cannot move Gear disengaged	-	R

¹⁾ Setpoint Relative in %:

Position Control Setpoint 0...100% refers to relative position 0...100%

Flow Control Setpoint 0...33% refers to range Vmax1...0 Setpoint 67...100% refers to 0...Vmax2
i.e. Setpoint 0% = Vmax1 / Setpoint 33% = 0 i.e. Setpoint 67% = 0 / Setpoint 100% = Vmax2

BACnet object description *(continued)*

Object Name	Object Type / Instance	Description	Values	Default	Access
Vmax1	AV [99]	Maximum Flow Limit of Seq1 in % <i>Related to Vnom</i>	0 ... 100	100	W
Vmax2	AV [100]	Maximum Flow Limit of Seq2 in % <i>Related to Vnom</i>	0 ... 100	100	W
Vnom_gpm	AV [102]	Nominal Volume Flow in gpm	Depending on DN size	-	R
Vnom_lh	AV [115]	Nominal Volume Flow in l/h	Depending on DN size	-	R
Vnom_UnitSel	AV [119]	Nominal Volume Flow in selected unit → <i>MV [121]</i>	Depending on DN size	-	R
ControlMode	MV [100]	Control Mode <i>The value defines the interpretation of the setpoint.</i>	PosCtrl FlowCtrl	FlowCtrl	W
UnitSelFlow	MV [121]	Unit Selection Flow <i>Defines the unit of the following objects</i> <i>AI [19]</i> <i>AI [109]</i> <i>AI [119]</i>	m ³ /s m ³ /h l/s l/min l/h gpm cfm	l/h	W
SpSource	MV [122]	Setpoint Source <i>The actuator has the possibility to be controlled from an analog input even though integrated on BACnet. Depending on this setting the setpoint by bus or analog input will be followed.</i> <i>Analog: Setpoint from analog signal 0...10V on wire 3</i> <i>Bus: Setpoint from BACnet → AO [1]</i>	Analog Bus	Analog	W

Modbus General Notes

General information	Protocol:	Modbus RTU / RS-485
	Number of nodes:	Max. 32 (without repeater)
	Transmission formats:	1-8-N-2, 1-8-N-1, 1-8-E-1, 1-8-O-1 <i>Default: 1-8-N-2</i>
	Baud rate:	9,600, 19,200, 38,400, 76,800, 115,200 Bd <i>Default: 38,400 Bd</i>
	Terminating resistor:	120 Ω (to be done with external resistor)
	Parameterisation:	With Belimo Assistant App

Register implementation All data is arranged in a table and addressed by 1..n (register) or 0..n-1 (address). No distinction is made between data types (Discrete Inputs, Coils, Input Registers and Holding Registers). As a consequence, all data can be accessed with the two commands for Holding Register. The commands for Discrete Inputs and Input Registers can be used as an alternative.

- Standard commands**
- Read Holding Registers [3]
 - Write Single Register [6]
 - Read Discrete Inputs [2]
 - Read Input Registers [4]
 - Write Multiple Registers [16]

Command "Read Discrete Inputs" The command reads one or more bits and can alternatively be used for Register No. 105 (Malfunction and Service information).
 Example The start address to be used is 1664 → **104 (Register Address) * 16 (Bit) = 1664**

Interpret values in the registers All values in the register are unsigned integer datatypes.
 Example Read (Function 03, 1 Register) Value Register No. 12 = 0001'1010'1100'1000₂ = 6'856₁₀
 Actual Value = Value * Scaling factor * Unit = 6'856 * 0.01 * m³/h = **68.56 m³/h**

32-Bit values in two registers Values that exceed 65,535 are stored in two consecutive Registers and have to be interpreted as "little endian" / LSW (Least Significant Word) first
 Example Register No. 10 (AbsFlow LowByte) = 14,551₁₀ = 0011'1000'1101'0111₂
 Register No. 11 (AbsFlow HighByte) = 19₁₀ = 0000'0000'0001'0011₂

AbsFlow HighByte	AbsFlow LowByte
19	14,551
0000'0000'0001'0011	0011'1000'1101'0111

→ AbsFlow = 0000'0000'0001'0011'0011'1000'1101'0111₂ = 1,259,735₁₀ = **1259.735 l/h**

Math formula:
 AbsFlow = (AbsFlow HighByte * 65,536) + AbsFlow LowByte
 AbsFlow = (19 * 65,536) + 14,551 = 1,259,735 = **1259.735 l/h**

Modbus Register Overview

	No.	Adr	Register	R/W	
In operation	1	0	Setpoint [%]	R/W	
	2	1	Override control	R/W	
	3	2	-	R	
	4	3	Actuator type	R	
	5	4	Relative position [%]	R	
	6	5	Absolute position [°]	R	
	7	6	Relative Flow [%]	R	
	8	7	Absolute Flow [UnitSel]	LData	R
	9	8		HData	
	10	9	Absolute Flow [l/h]	LData	R
	11	10		HData	
	12	11	Absolute Flow [gpm]	LData	R
	13	12		HData	
	14	13	Setpoint Absolute Flow [UnitSel]	LData	R
	15	14		HData	
	16	15	Setpoint Analog [V]	R	
	17	16	Active Sequence	R	
Service	101	100	Series number 1 st part	R	
	102	101	Series number 2 nd part		
	103	102	Series number 4 th part		
	104	103	Firmware version	R	
	105	104	Malfunction & Service information	R	
	106	105	Vmax Sequence 1 [%]	R/W	
	107	106	Vmax Sequence 2 [%]	R/W	
	108	107	-		
	109	108	-		
	110	109	-		
	111	110	Absolute Vnom [UnitSel]	LData	R
	112	111		HData	
	113	112	Absolute Vnom [l/h]	LData	R
	114	113		HData	
	115	114	Absolute Vnom [gpm]	LData	R
	116	115		HData	
	117	116	Control Mode	R/W	
	118	117	Unit Selection Flow	R/W	
	119	118	Setpoint Source	R/W	

Modbus Register Description

**Register 1:
Setpoint** Setpoint for actuator setting in hundredths of one percent
Scaling factor: 0.01 → i.e. 0...10,000 corresponds to 0...100%

Position Control Setpoint 0...100% refers to relative position 0...100%

Flow Control Setpoint 0...33% refers to range $V_{max1} \dots 0$
i.e. Setpoint 0% = V_{max1} / Setpoint 33% = 0
Setpoint 67...100% refers to $0 \dots V_{max2}$
i.e. Setpoint 67% = 0 / Setpoint 100% = V_{max2}

**Register 2:
Override control** Overriding the setpoint (Register No. 1) with defined values

0	None
1	Open Sequence 1 (0%)
2	Open Sequence 2 (100%)
3	Close (50%)
4	V_{max} Sequence 1
5	V_{max} Sequence 2

**Register 3:
(Reserved)** Not used in this device. Constant value 65'535

**Register 4:
Actuator type** Actuator type; the allocation may deviate from the basic category with some actuators.

0	Unknow
1	Air & Water
2	EPIV / VAV
3	Fire
4	EnergyValve
5	6way EPIV

**Register 5:
Relative position** Relative position of actuator in hundredths of one percent [%]
Scaling factor: 0.01 → i.e. 0...10,000 corresponds to 0...100%

**Register 6:
Absolute Position** Absolute position of actuator in hundredths of one degree [°]
Scaling factor: 0.01 → i.e. 0 ... 9,000 corresponds to 0...90°

**Register 7:
Relative Flow** Relative flow in hundredths of one percent of active V_{max} (V_{max1} or V_{max2})
Scaling factor: 0.01 → i.e. 0 ... 10,000 correspond to 0 ... 100%

**Register 8/9:
Absolute Flow UnitSel** Absolute Flow in unit which is selected in Register No. 118
Scaling factor: 0.001

**Register 10/11:
Absolute Flow in l/h** Absolute Flow in l/h
Scaling factor: 0.001 → i.e. 1,260,000 corresponds to 1,260.000 l/h

**Register 12/13:
Absolute Flow in gpm** Absolute Flow in gpm
Scaling factor: 0.001 → i.e. 1,200 corresponds to 1.200 gpm

**Register 14/15:
Setpoint Absolute Flow UnitSel** Setpoint as Absolute Flow in unit which is selected in Register No. 118
Scaling factor: 0.001

**Register 16:
Setpoint Analog** Setpoint as analog value in hundredths of a Volt
i.e 0...1,000 corresponds to 0.00...10.00V

**Register 17:
Active Sequence** Indicates Active Sequence

0	Sequence 1 (0...33%)
1	Sequence 2 (67...100%)
2	Dead Band (34...66%)

Register 101-103: Each device has an unambiguous series number which is either impressed on or glued to the housing. The series number consists of 4 segments, although only parts 1, 2 and 4 are displayed on Modbus.
Series number Example: 00839-31324-064-008

Register 101	Register 102	Register 103
1 st part	2 nd part	4 th part
00839	31234	008

Register 104: Firmware version of Modbus module (VX.XX)
Firmware Version e.g. 101 V1.01

Register 105: The status information is split into messages about the actuator (malfunctions) and other service information
Malfunction and service information

Bit	Description
0	-
1	-
2	Error flow sensor
3	Actuator can't move
4	Flow with closed valve
5	Airbubbles
6	Flow not reached
7	-
8	-
9	Gear disengagement active
10	-
11	-
12	-
13	-
14	-
15	-

Description

- Error Flow Sensor: Error with the flow sensor
- Actuator can't move: Mechanical overload due to blocked valve, etc.
- Flow with closed valve: Flow is measured but position of valve is closed (Dead Band)
- Airbubbles: Airbubbles in the hydronic system
- Flow not reached: Setpoint cannot be reached within 3min during flow control
- Gear disengagement active: Gear disengaged button is pressed

Register 106: Maximum limit of Flow of Sequence 1 in hundredths of one percent of Vnom
Vmax of Sequence 1 Scaling factor: 0.001 → i.e. 50...10,000 correspond to 5...100%

Register 107: Maximum limit of Flow of Sequence 2 in hundredths of one percent of Vnom
Vmax of Sequence 2 Scaling factor: 0.001 → i.e. 50...10,000 correspond to 5...100%

Register 108: Not used in this device. Constant value 65'535
(Reserved)

Register 109: Not used in this device. Constant value 65'535
(Reserved)

Register 110: Not used in this device. Constant value 65'535
(Reserved)

Register 111/112: Nominal volume in selected unit in Register No. 118
Vnom in UnitSel Scaling factor: 0.001

Register 113/114: Nominal volume in l/h
Vnom in l/h Scaling factor: 0.001 → i.e. 350 corresponds to 0.350 l/h

Register 115/116: Nominal volume in gpm
Vnom in gpm Scaling factor: 0.001 → i.e. 1,200 corresponds to 1.200 gpm

Register 117: Control Mode of the EPIV. Further information see Register No. 1 (Setpoint)
Control mode

0	Position Control
1	Flow Control

Register 118: Selection of Flow Unit defines unit of Register No. 8/9, 14/15, 111/112
Unit Selection Flow

0	m ³ /s
1	m ³ /h
2	l/s
3	l/min
4	l/h
5	gpm
6	cfm

Register 119: Source of setpoint. The actuator has the possibility to be controlled from an analog input even though integrated on Modbus. Depending on this setting the setpoint by bus or analog input will be followed.
Setpoint Source

0	Analog
1	Bus

Description Analog: Setpoint from analog signal 0...10V on wire 3
 Bus: Setpoint from Modbus → Register No. 1

6-Way CCV

A valve designed for chilled beams, radiant ceiling panels, and 4-pipe fan coil units. It has the functionality of up to four 2-way control valves.

6-Way ePIV

Like the 6-way CCV, but with furnished ultrasonic flow meter and pressure independent flow logic within the actuator. It has the functionality of up to four 2-way control valves and two balancing valves.

Analog

A linear signal from one device to another. Used to move or read values. It is used by a controller to modulate an actuator. Typical analog signal range is 2-10 VDC, 0-10 VDC, or 4-20 mA.

BACnet

A standard world-wide communication protocol that is used in building automation. BACnet uses two common communication mechanisms, BACnet IP which communicates over Ethernet networks. BACnet MS/TP communicates over 2 or 3-wire RS485 networks.

BAS

(Building Automation System)

A computer-based control system installed in buildings to control and monitor the building's mechanical and electrical equipment.

CCV

(Characterized Control Valve)

Belimo patented ball valve with characterizing disc that is designed to provide a linear coil flow output.

Deadband

Both Sequence 1 & 2 have zero flow to the coil. This occurs between 4.7 to 7.3 VDC, and from 30° to 60° valve rotation.

DDC

(Direct Digital Control)

A controller with software to operate control valves, dampers and other devices.

ePIV

(Electronic Pressure Independent Control Valve)

The ePIV directly measures flow by combining an electronic flow meter and a control valve. The actuator has a powerful algorithm that modulates the control valve to maintain the flow setpoint from the DDC controller. The flow reading is reported back to the controller using a standard analog signal, and this value can be used by the BAS to perform advanced control and energy strategies.

Modbus RTU

Used in serial communication and makes use of a compact, binary representation of the data for protocol communication. The RTU format follows the commands/data with a cyclic redundancy check checksum as an error check mechanism to ensure the reliability of data. Modbus RTU is the most common implementation available for Modbus. A Modbus RTU message must be transmitted continuously without inter-character hesitations. Modbus messages are framed (separated) by idle (silent) periods. (Wikipedia 17Aug2017)

MP-Bus (MP)

Belimo communication protocol. The ZTH US tool uses this protocol to view and change actuator settings.

Sequence 1

Maximum to minimum flow for either heating or cooling flow to the coil. This occurs between 2.0 to 4.7 VDC, and from 0° to 30° valve rotation.

Sequence 2

Minimum to maximum flow for either cooling or heating flow to the coil. This occurs between 7.3 to 10.0 VDC, and from 60° to 90° valve rotation.

True Flow

Flow signal from the ultrasonic flow meter.

Ultrasonic Flow Meter

Utilizing ultrasonic transit time technology, the transducers perform as both emitter and receiver while acoustic mirrors provide accurate signal reflection. The flow meter also incorporates an embedded temperature sensor which enables Belimo's patented temperature and glycol compensation logic to accurately read flow over a wide range of water variables.

V'max

The maximum flow setting for sequence 1 and sequence 2, which is equal to or less than V'nom. Flow settings can be different for each sequence.

V'nom

The maximum allowable flow for sequence 1 and sequence 2.